

# WHAT'S IN YOUR BOX?™

## HERE IS WHAT'S IN OURS

### Completely Assembled

Inside the Tech Expert® box, you'll find an Oil Filter Housing Kit that is factory-assembled. Each housing includes a new oil pressure sensor, oil temperature sensor, oil cooler, the correct year/make/model-specific oil filter, new gaskets and seals already installed. Our Oil Filter Housing Kits also include the intake manifold gaskets needed for a complete repair.



### Design Improvements

The original oil filter housings on the Pentastar V6 have multiple weak points where oil can leak from. Our engineers evaluated the original units and designed housings with multiple improvements over the original to address the OE weak points. Additionally, our housing is constructed using Zytel®, a high-strength, synthetic material.



### Correct Cooling

Our Oil Filter Housings are designed to match the thermal characteristics of the original design. This is critical as these housings are not only oil filters, but also oil coolers. When the OE developed the oil cooling system to use a high-temp synthetic housing, that is what we deliver, and when the OE uses aluminum, we use aluminum.



### Correct Offering

While different generations of Pentastar oil filter housings do look the same, there are functional differences in their design. Tech Expert® always matches OE design and performance by using oil filters with the correct flow rate and the correct oil pressure sensors. Universal housings may not match OE performance for every vehicle model-year that they are cataloged for.



## THE FACTORY-ASSEMBLED, DROP-IN SOLUTION

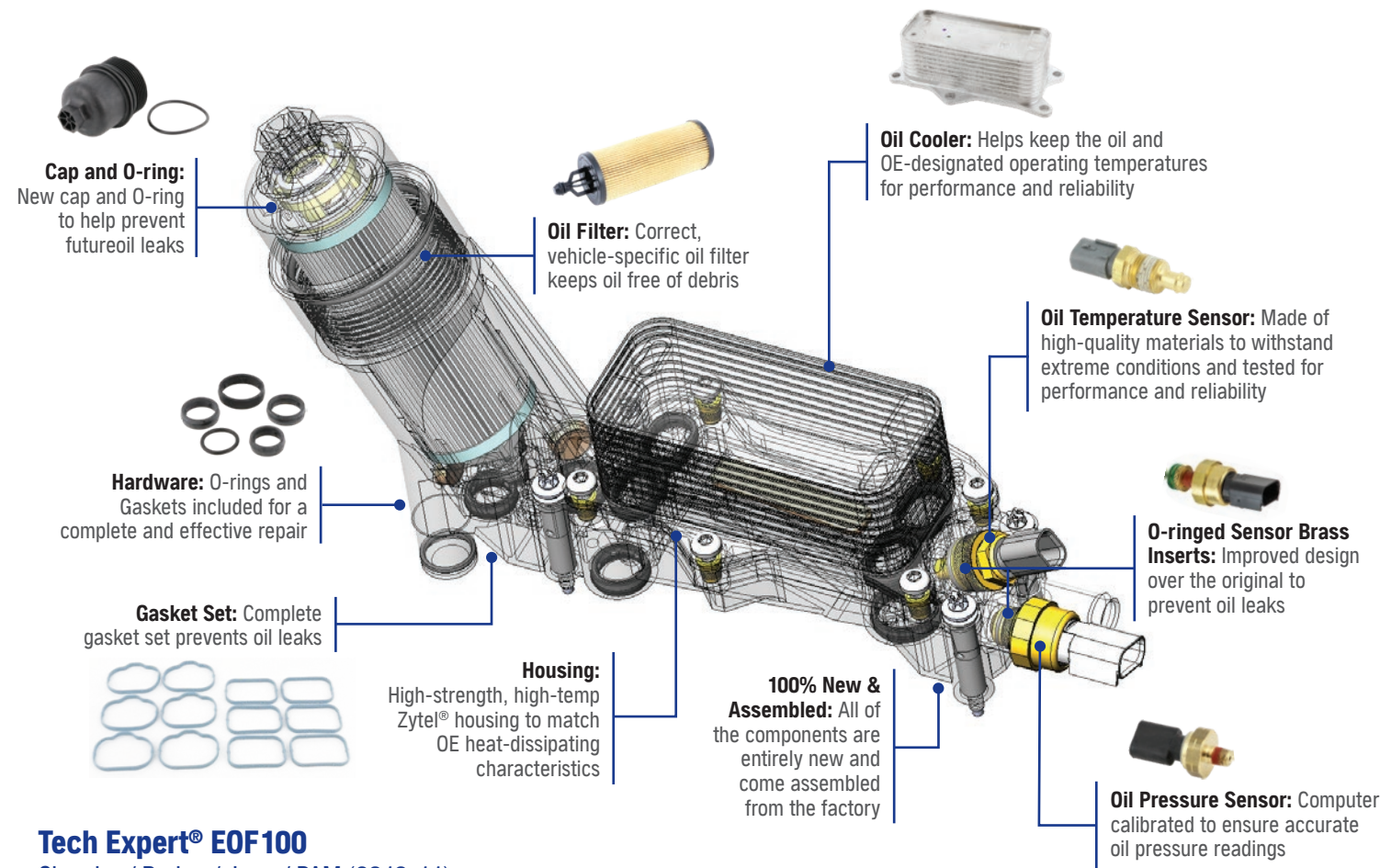

**Tech Expert® EOF100**  
Chrysler / Dodge / Jeep / RAM (2013-11)

In addition to six different housings for the Pentastar V6, we also offer Oil Filter Housings and Oil Coolers for other import and domestic vehicles.



**EOF106**  
Volvo Cars & SUVs (2016-04)  
VIO: 206K



**EOF107**  
Volvo Cars & SUVs (2014-07)  
VIO: 87K



**EOF109**  
Buick / Chevrolet Cars (2021-11)  
VIO: 2.2M

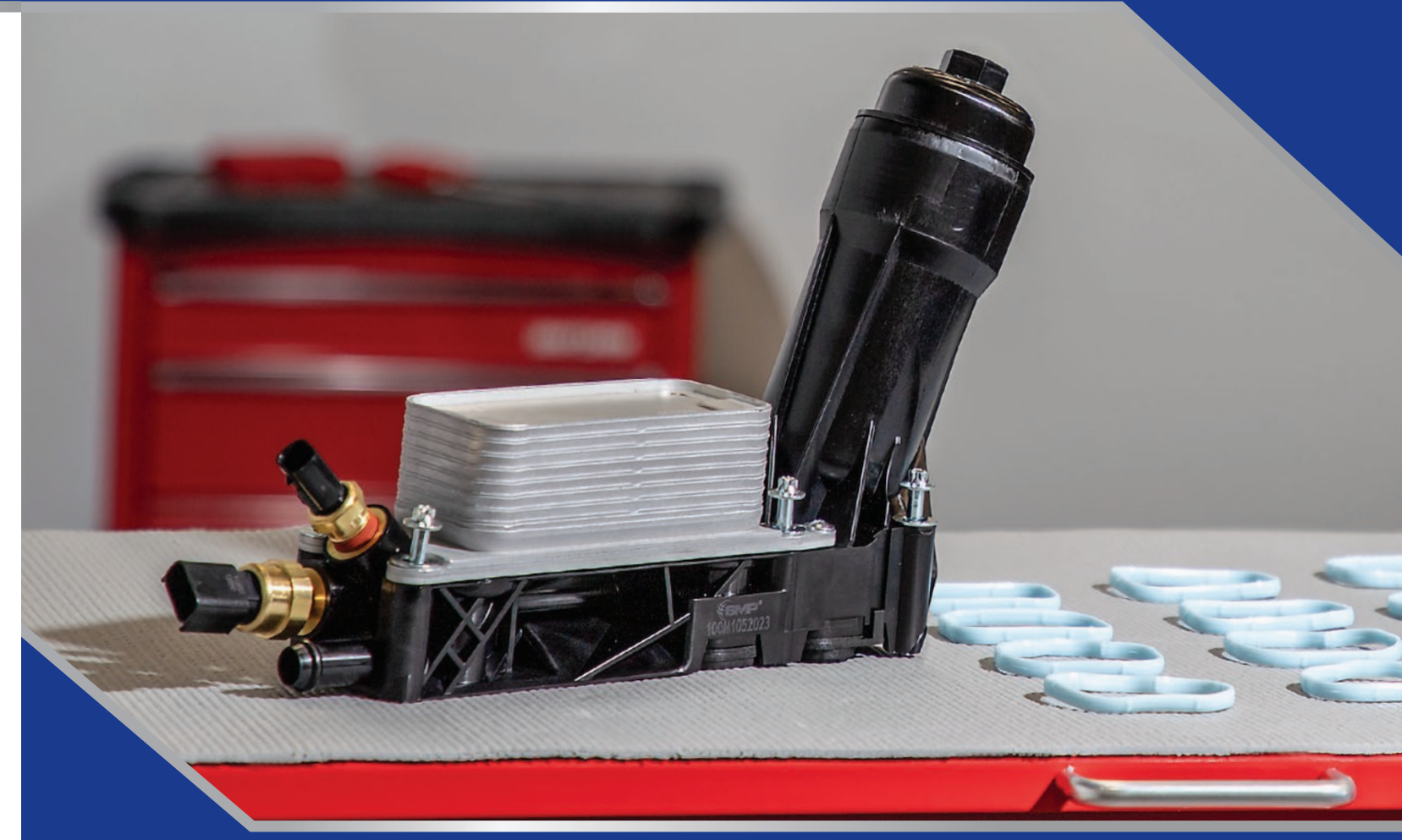

# OIL FILTER HOUSING KITS



Expert Solutions for Professional Technicians™



## Pentastar Oil Filter Housings

While oil filter housings on Pentastar V6 engines may all look similar, there are distinct differences between model years, like oil filter flow rates as well as temperature and pressure sensor changes.

Universal designs may not be correct for every application!

Tech Expert® PN	Year Range*	OEM Oil Pressure Sensor	OEM Oil Temp. Sensor	Oil Filter Flow Rate
EOF100	2013-2011	5149062AA	5149077AB	12L / Minute
EOF101	2016-2014	5149062AA	5149077AB	10L / Minute
EOF136	2018-2016	68295556AA	None	10L / Minute
EOF103	2019-2017	68295556AA	5149077AB	10L / Minute
EOF104	2022-2019	68334877AA	5149077AB	10L / Minute
EOF111	2024-2022	68334877AA	None	10L / Minute

*\*Varies by actual vehicle make & model*

## They don't just filter the oil, they also cool it

Modular oil filter housings are becoming increasingly popular on modern vehicles replacing the older spin-on style filters. It is important to remember, they don't just filter the oil, they also cool it!

- Housings contain passages for both oil and coolant
- These passages are very close together – one failed seal can cause cross-contamination
- It is critical that a replacement unit matches the thermal characteristics of the original design to help keep the oil cool

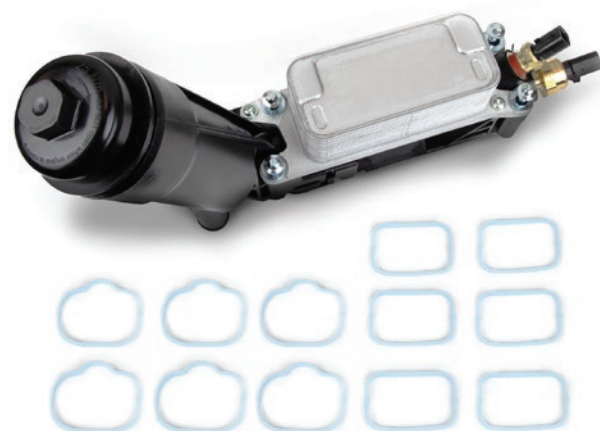

### OE Problem:

Oil leaks from the back of the housing around the core plugs that are installed without any seals or O-rings.



### Tech Expert® Solution:

Tech Expert® installs an O-ring on each core plug before ultrasonically welding them into the housing. This creates a positive, long-lasting seal.

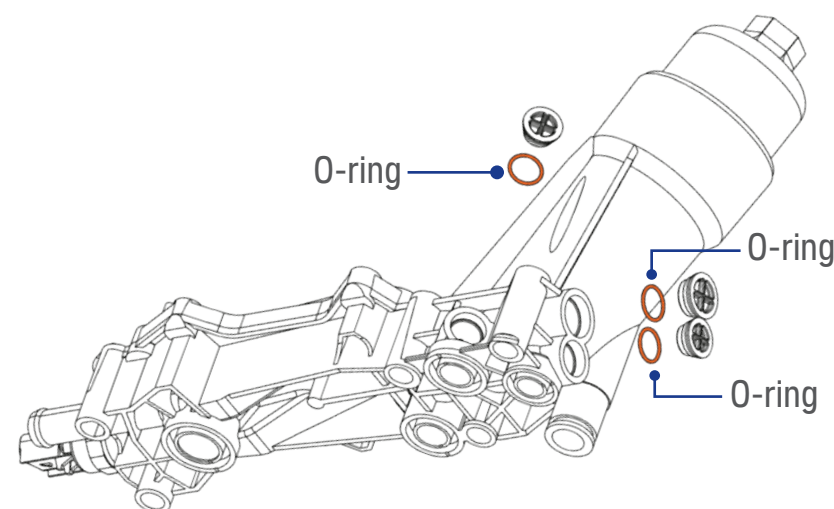

### OE Problem:

Oil leaks from the brass sensor inserts because there is not an effective seal between the brass and the synthetic housing material.



### Tech Expert® Solution:

Additional O-rings are installed on our knurled brass inserts to prevent oil leaks. The sensors are then installed and torqued to specification in a controlled, contaminant-free environment.

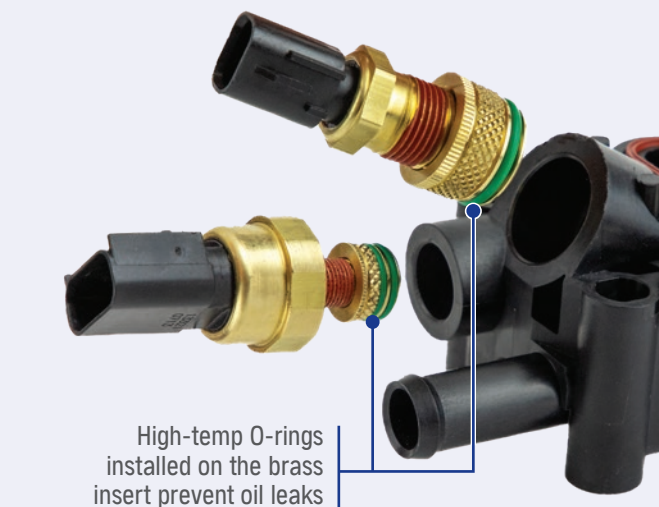

### OE Problem:

Oil contaminates the coolant causing cooling system problems, resulting in overheating and premature radiator failure. This is because there is no seal on the core plug that separates the oil and coolant passages.



### Tech Expert® Solution:

We added a robust seal to the core plug which separates these two passages. This enhancement prevents an internal failure and cross-contamination.

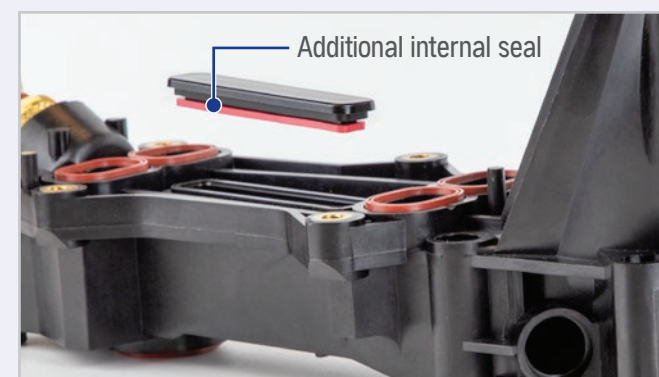

### OE Problem:

The OE seals often become distorted or crushed, resulting in an oil leak around the base of the housing.



### Tech Expert® Solution:

We install new, distortion-resistant seals. The synthetic material on the seals is less prone to failure than the original.

